

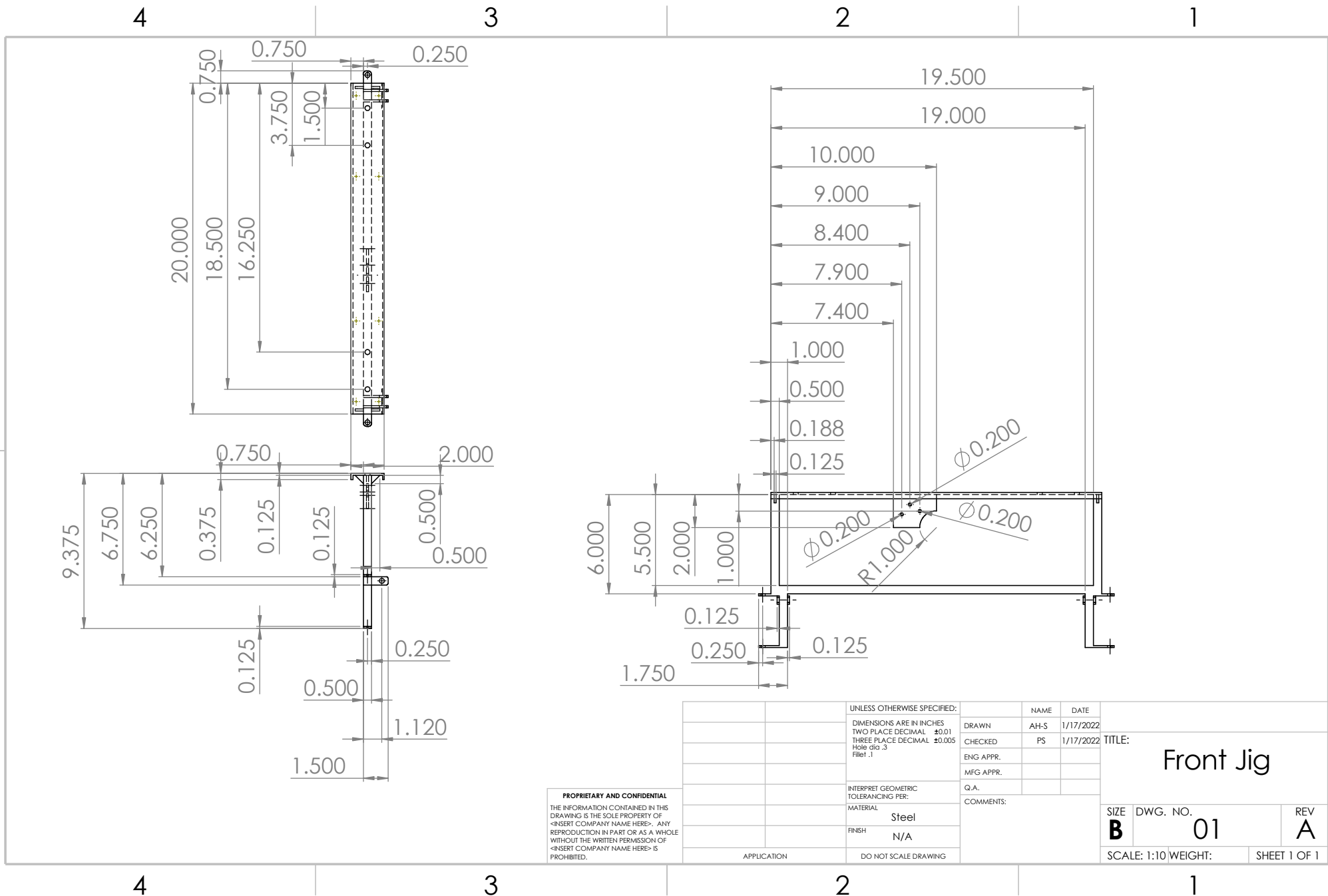

**Blueprints**



**PROPRIETARY AND CONFIDENTIAL**  
 THE INFORMATION CONTAINED IN THIS DRAWING IS THE SOLE PROPERTY OF <INSERT COMPANY NAME HERE>. ANY REPRODUCTION IN PART OR AS A WHOLE WITHOUT THE WRITTEN PERMISSION OF <INSERT COMPANY NAME HERE> IS PROHIBITED.

UNLESS OTHERWISE SPECIFIED:		NAME	DATE	TITLE: <b>Front Jig</b>	
DIMENSIONS ARE IN INCHES		DRAWN	AH-S		1/17/2022
TWO PLACE DECIMAL ±0.01		CHECKED	PS		1/17/2022
THREE PLACE DECIMAL ±0.005		ENG APPR.			
HOLD DIM. 3		MFG APPR.			
FILET .1		Q.A.			
INTERPRET GEOMETRIC TOLERANCING PER:		COMMENTS:			
MATERIAL		Steel		SIZE	
FINISH		N/A		DWG. NO.	
APPLICATION		DO NOT SCALE DRAWING		<b>B</b>	
				<b>01</b>	
				REV	
				<b>A</b>	
				SCALE: 1:10 WEIGHT:	
				SHEET 1 OF 1	



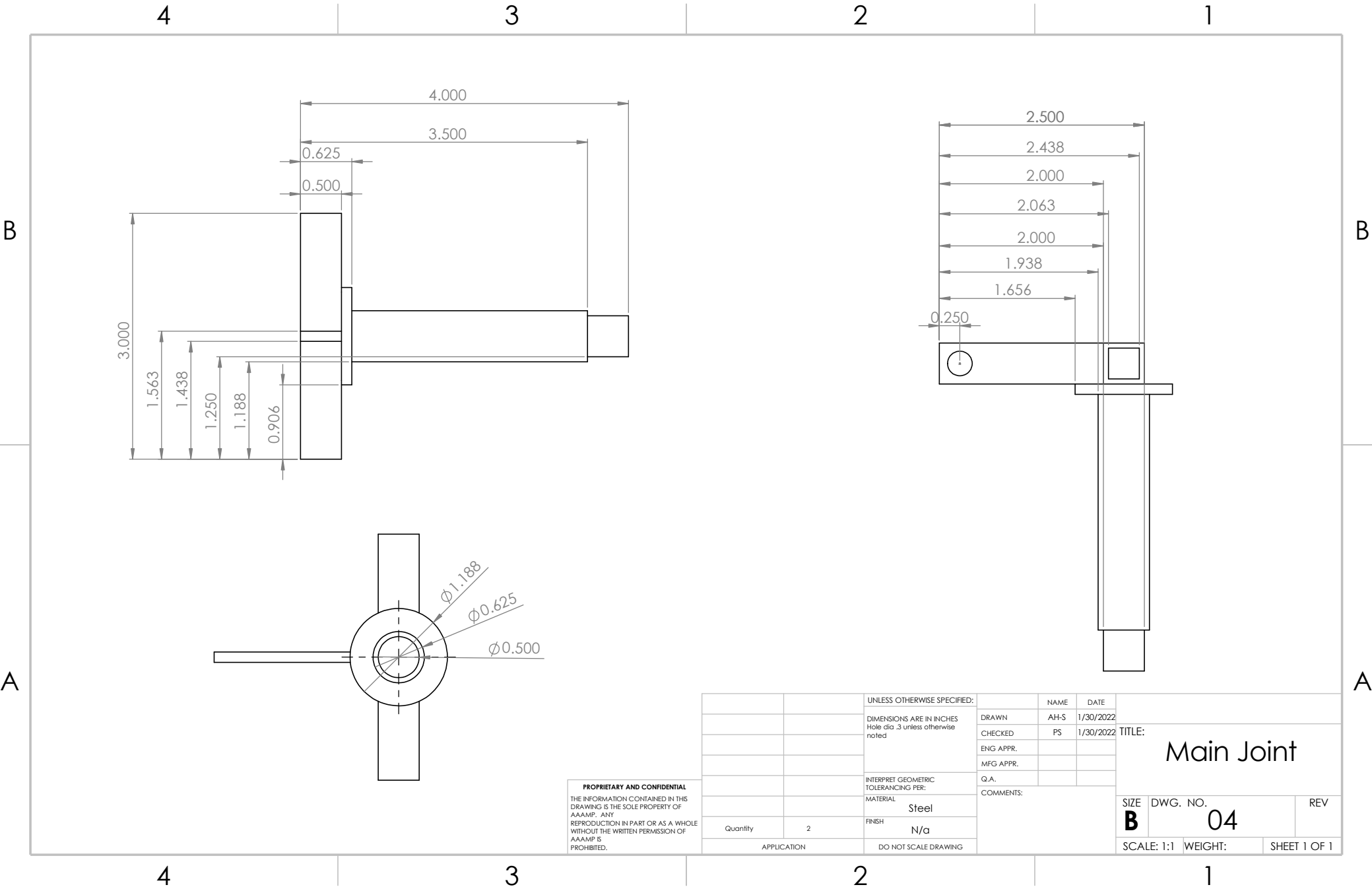

**PROPRIETARY AND CONFIDENTIAL**  
 THE INFORMATION CONTAINED IN THIS DRAWING IS THE SOLE PROPERTY OF AAAMP. ANY REPRODUCTION IN PART OR AS A WHOLE WITHOUT THE WRITTEN PERMISSION OF AAAMP IS PROHIBITED.

		UNLESS OTHERWISE SPECIFIED:		NAME	DATE		
		DIMENSIONS ARE IN INCHES Hole dia .3 unless otherwise noted		DRAWN	AH-5	1/30/2022	TITLE: <b>Main Joint</b>
				CHECKED	PS	1/30/2022	
				ENG APPR.			
				MFG APPR.			
		INTERPRET GEOMETRIC TOLERANCING PER:		Q.A.			SIZE DWG. NO. REV <b>B</b> <b>04</b>
		MATERIAL		COMMENTS:			
		Steel					
Quantity	2	FINISH				SCALE: 1:1 WEIGHT: SHEET 1 OF 1	
APPLICATION		DO NOT SCALE DRAWING					

2 1

B

B

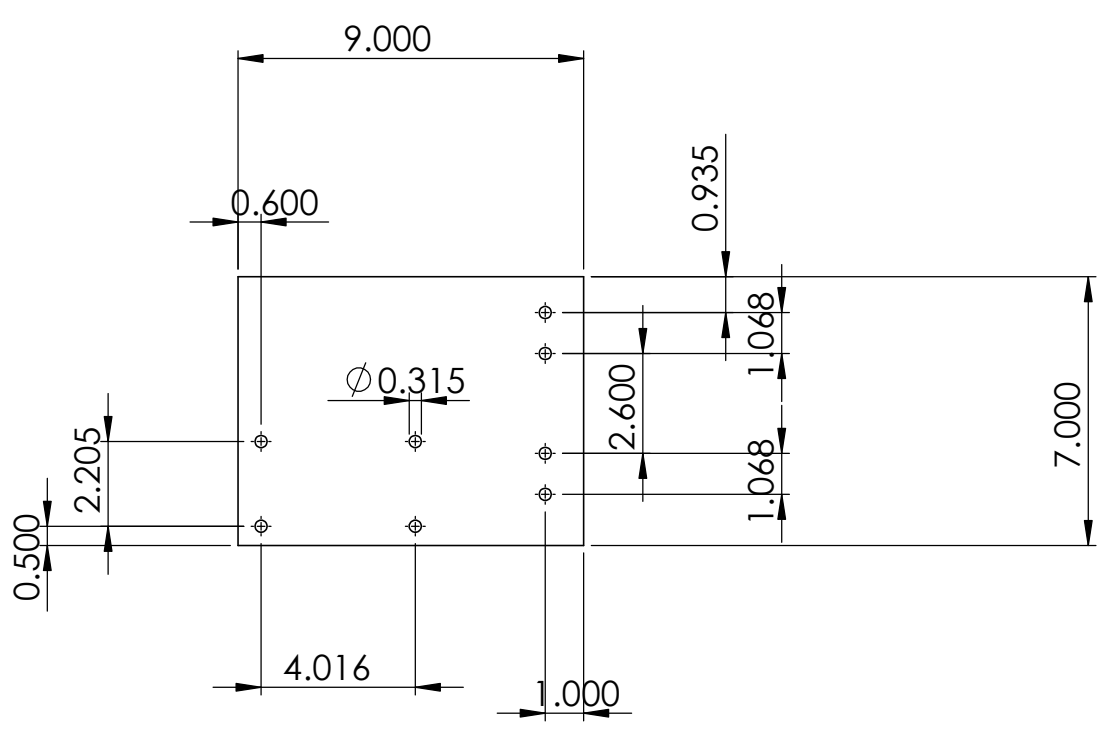

A

A

**PROPRIETARY AND CONFIDENTIAL**  
 THE INFORMATION CONTAINED IN THIS DRAWING IS THE SOLE PROPERTY OF AAAMP. ANY REPRODUCTION IN PART OR AS A WHOLE WITHOUT THE WRITTEN PERMISSION OF AAAMP IS PROHIBITED.

		UNLESS OTHERWISE SPECIFIED:		NAME	DATE
		DIMENSIONS ARE IN INCHES	DRAWN	ARH	3/3/22
		TOLERANCES:	CHECKED	AHS	3/3/22
		THREE PLACE DECIMAL ±0.050	ENG APPR.		
			MFG APPR.		
		INTERPRET GEOMETRIC TOLERANCING PER:	Q.A.		
		MATERIAL	COMMENTS:		
		CR Steel			
NEXT ASSY	USED ON	FINISH			
		N/A			
APPLICATION		DO NOT SCALE DRAWING			

TITLE:		
Basket Plate		
SIZE	DWG. NO.	REV
<b>A</b>	11	<b>A</b>
SCALE: 1:5	WEIGHT:	SHEET 1 OF 1

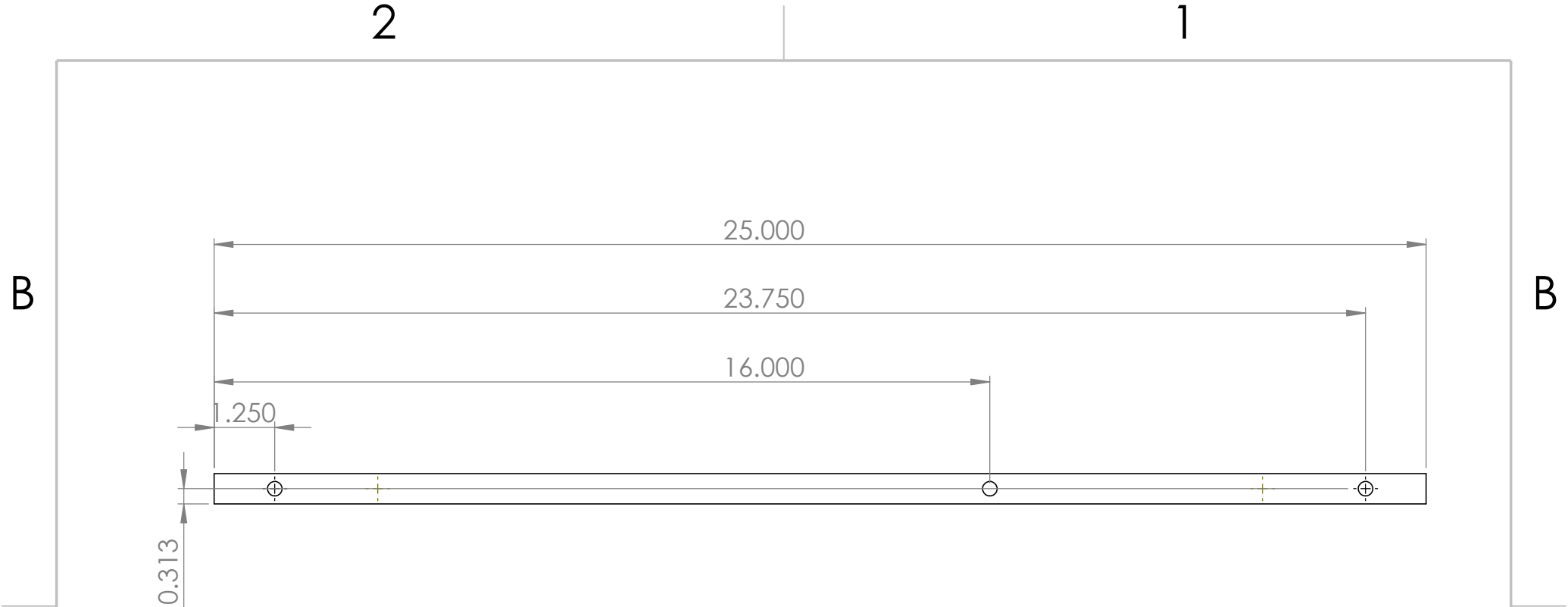

<p><b>PROPRIETARY AND CONFIDENTIAL</b> THE INFORMATION CONTAINED IN THIS DRAWING IS THE SOLE PROPERTY OF AAAMP. ANY REPRODUCTION IN PART OR AS A WHOLE WITHOUT THE WRITTEN PERMISSION OF AAAMP IS PROHIBITED.</p>			UNLESS OTHERWISE SPECIFIED:		NAME	DATE	<p>TITLE: <b>Rear Axle</b></p>
			DIMENSIONS ARE IN INCHES Hole dia. .3 unless otherwise noted	DRAWN	AH	1/31/2022	
				CHECKED	AH-S	1/31/2022	
				ENG APPR.			
				MFG APPR.			
			INTERPRET GEOMETRIC TOLERANCING PER:	Q.A.			
			MATERIAL	COMMENTS:			
			FINISH				
	NEXT ASSY	USED ON	Steel				
			N/A				
	APPLICATION		DO NOT SCALE DRAWING				
				SIZE	DWG. NO.	REV	
				<b>A</b>	<b>12</b>		
				SCALE: 1:5	WEIGHT:	SHEET 1 OF 1	

2

1

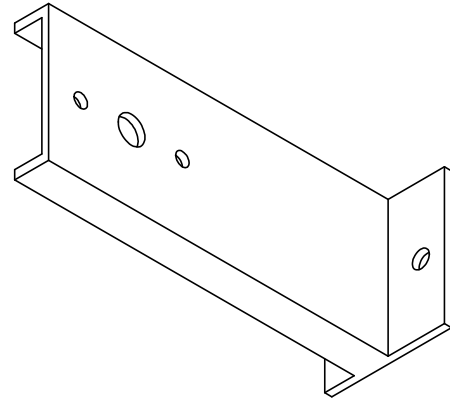
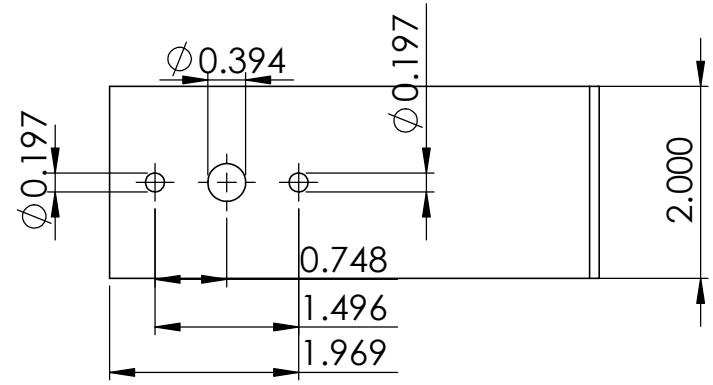
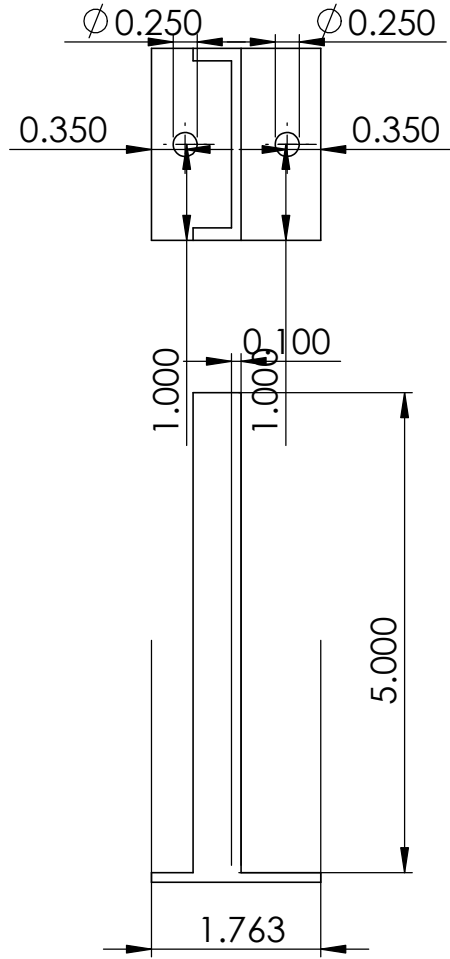

B

B

A

A

**PROPRIETARY AND CONFIDENTIAL**  
 THE INFORMATION CONTAINED IN THIS DRAWING IS THE SOLE PROPERTY OF AAAMP. ANY REPRODUCTION IN PART OR AS A WHOLE WITHOUT THE WRITTEN PERMISSION OF AAAMP IS PROHIBITED.

		UNLESS OTHERWISE SPECIFIED:		NAME	DATE
		DIMENSIONS ARE IN INCHES TOLERANCES: THREE PLACE DECIMAL ±0.005	DRAWN	ARH	2/25/22
			CHECKED	AHS	2/25/22
			ENG APPR.		
			MFG APPR.		
		INTERPRET GEOMETRIC TOLERANCING PER:	Q.A.		
		MATERIAL STEEL	COMMENTS:		
		FINISH N/A			
NEXT ASSY	USED ON				
APPLICATION		DO NOT SCALE DRAWING			

TITLE: <b>Mid-Train Axle Mounts</b>		
SIZE <b>A</b>	DWG. NO. 15	REV <b>A</b>
SCALE: 1:2	WEIGHT:	SHEET 1 OF 1

1

2

1

B

B

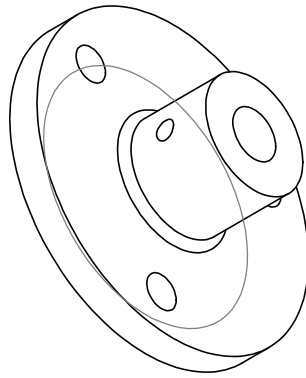
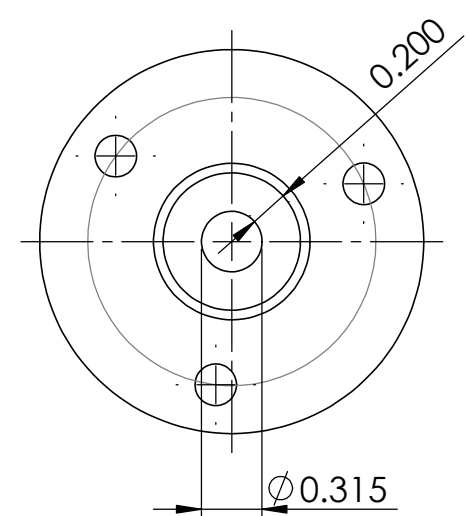
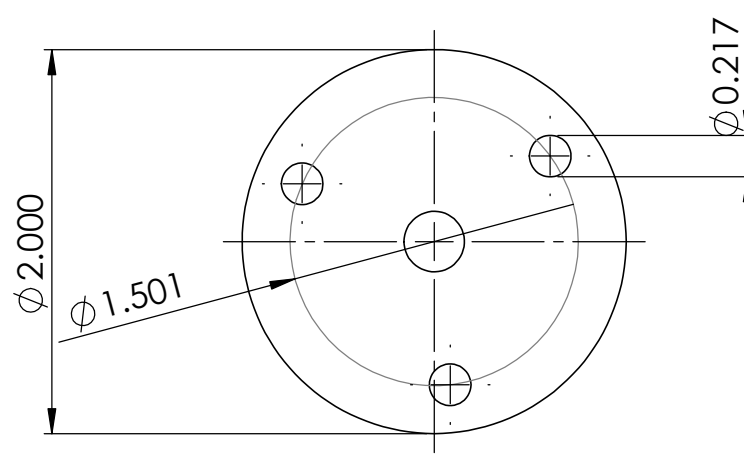
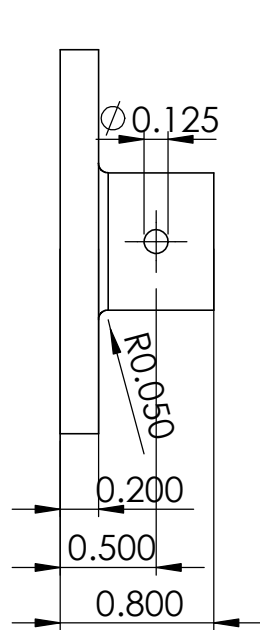

A

A

**PROPRIETARY AND CONFIDENTIAL**  
 THE INFORMATION CONTAINED IN THIS DRAWING IS THE SOLE PROPERTY OF AAAMP. ANY REPRODUCTION IN PART OR AS A WHOLE WITHOUT THE WRITTEN PERMISSION OF AAAMP IS PROHIBITED.

		UNLESS OTHERWISE SPECIFIED:		NAME	DATE
		DIMENSIONS ARE IN INCHES	DRAWN	ARH	3/1/22
		TOLERANCES:	CHECKED	AHS	3/1/22
		THREE PLACE DECIMAL ±0.005	ENG APPR.		
			MFG APPR.		
		INTERPRET GEOMETRIC TOLERANCING PER:	Q.A.		
		MATERIAL	COMMENTS:		
		Aluminum			
NEXT ASSY	USED ON	FINISH			
		N/A			
APPLICATION		DO NOT SCALE DRAWING			

TITLE:		
<b>Axle Hub - Midtrain</b>		
SIZE	DWG. NO.	REV
<b>A</b>	<b>16</b>	<b>A</b>
SCALE: 1:1	WEIGHT:	SHEET 1 OF 1

1



B

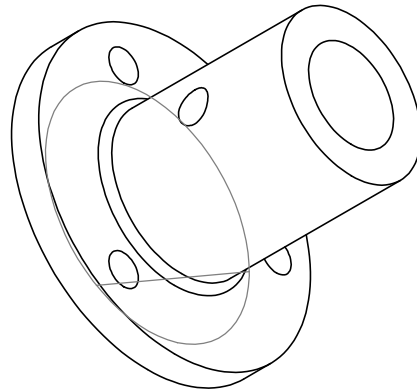
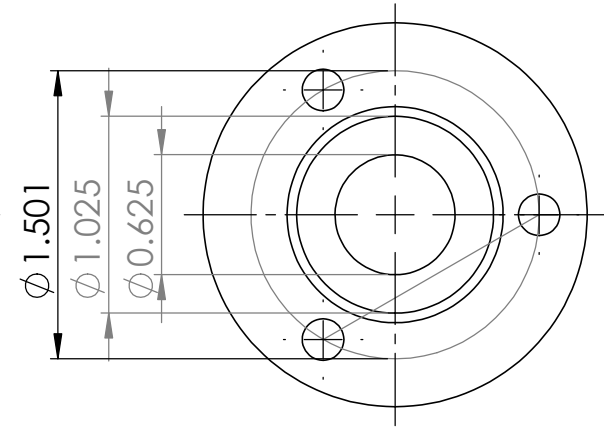
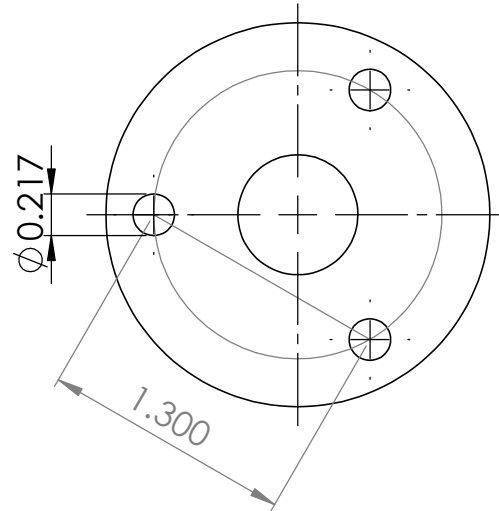
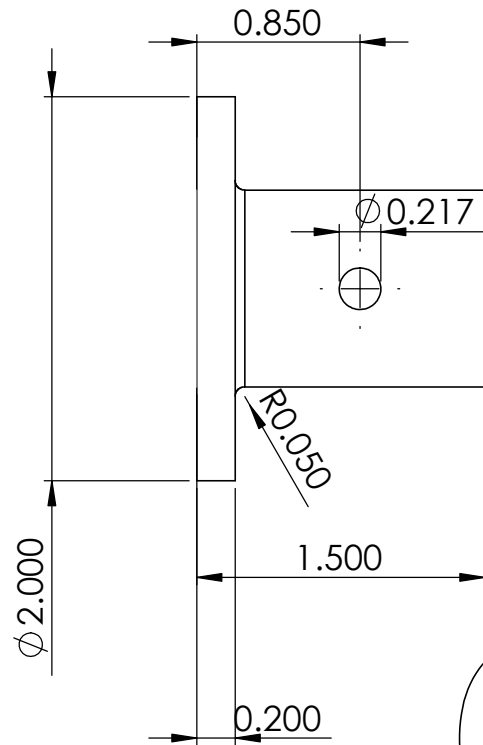

B

A

A

**PROPRIETARY AND CONFIDENTIAL**  
 THE INFORMATION CONTAINED IN THIS DRAWING IS THE SOLE PROPERTY OF AAAMP. ANY REPRODUCTION IN PART OR AS A WHOLE WITHOUT THE WRITTEN PERMISSION OF AAAMP IS PROHIBITED.

		UNLESS OTHERWISE SPECIFIED:		NAME	DATE	TITLE: <b>Hub Mount - Rear Axle</b>			
		DIMENSIONS ARE IN INCHES TOLERANCES: THREE PLACE DECIMAL ±0.005	DRAWN	ARH	3/1/22			SIZE	DWG. NO.
			CHECKED	AHS	3/1/22			<b>A</b>	<b>17</b>
			ENG APPR.						REV
			MFG APPR.						<b>A</b>
		INTERPRET GEOMETRIC TOLERANCING PER:	Q.A.			SCALE: 1:1			
		MATERIAL Aluminum	COMMENTS:			WEIGHT:	SHEET 1 OF 1		
NEXT ASSY	USED ON	FINISH N/A							
APPLICATION		DO NOT SCALE DRAWING							