

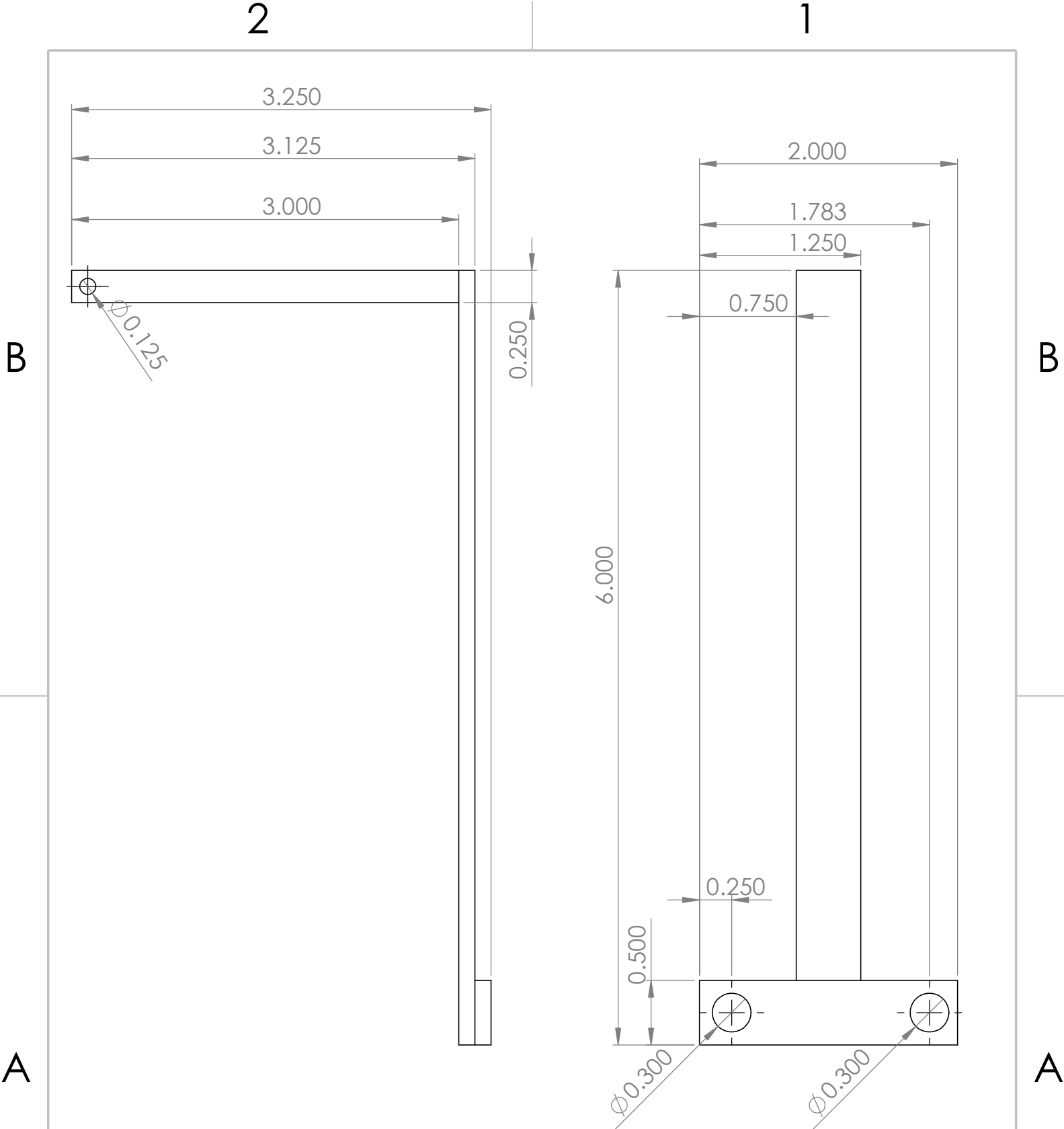

Blueprints



		DIMENSIONS ARE IN INCHES	NAME	DATE
			DRAWN	AH-S 1/24/2022
			CHECKED	PS 1/30/2022
			ENG APPR.	
			MFG APPR.	
		MATERIAL	Q.A.	
		Steel	COMMENTS:	
		FINISH		
		N/A		
APPLICATION		DO NOT SCALE DRAWING		

<h1>Pivot Arm</h1>			REV.
SIZE	DWG. NO.		
A	02		
SCALE:1:2	WEIGHT:		SHEET 1 OF 1

PROPRIETARY AND CONFIDENTIAL
 THE INFORMATION CONTAINED IN THIS DRAWING IS THE SOLE PROPERTY OF AAAMP. ANY REPRODUCTION IN PART OR AS A WHOLE WITHOUT THE WRITTEN PERMISSION OF AAAMP IS PROHIBITED.

2

1

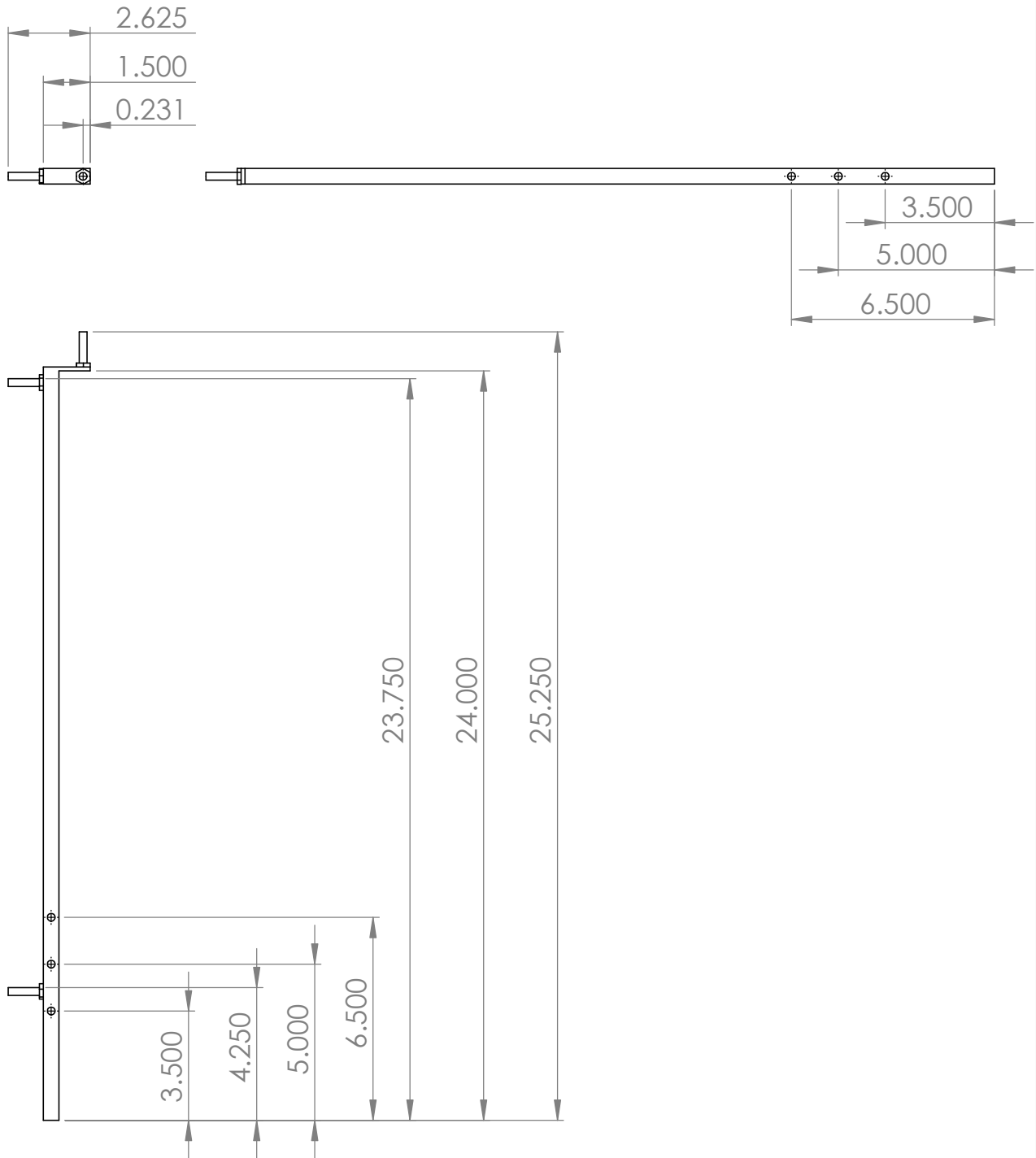

B

B

A

A

		DIMENSIONS ARE IN INCHES All Holes are 0.25" in diameter		NAME	DATE	Left Front Solar Mount
				DRAWN	AH-S 1/30/2022	
				CHECKED	PS 1/30/2022	
				ENG APPR.		
				MFG APPR.		
		MATERIAL		Q.A.		SIZE DWG. NO. REV. A 05
		Steel		COMMENTS:		
		FINISH		Uses 1"x1/4" bolts welded on		
NEXT ASSY	USED ON	N/A		SCALE:1:10		WEIGHT:
APPLICATION		DO NOT SCALE DRAWING		SHEET 1 OF 1		

PROPRIETARY AND CONFIDENTIAL
 THE INFORMATION CONTAINED IN THIS DRAWING IS THE SOLE PROPERTY OF AAAMP. ANY REPRODUCTION IN PART OR AS A WHOLE WITHOUT THE WRITTEN PERMISSION OF AAAMP IS PROHIBITED.

1

2

1

B

B

A

A

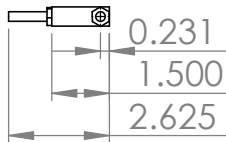
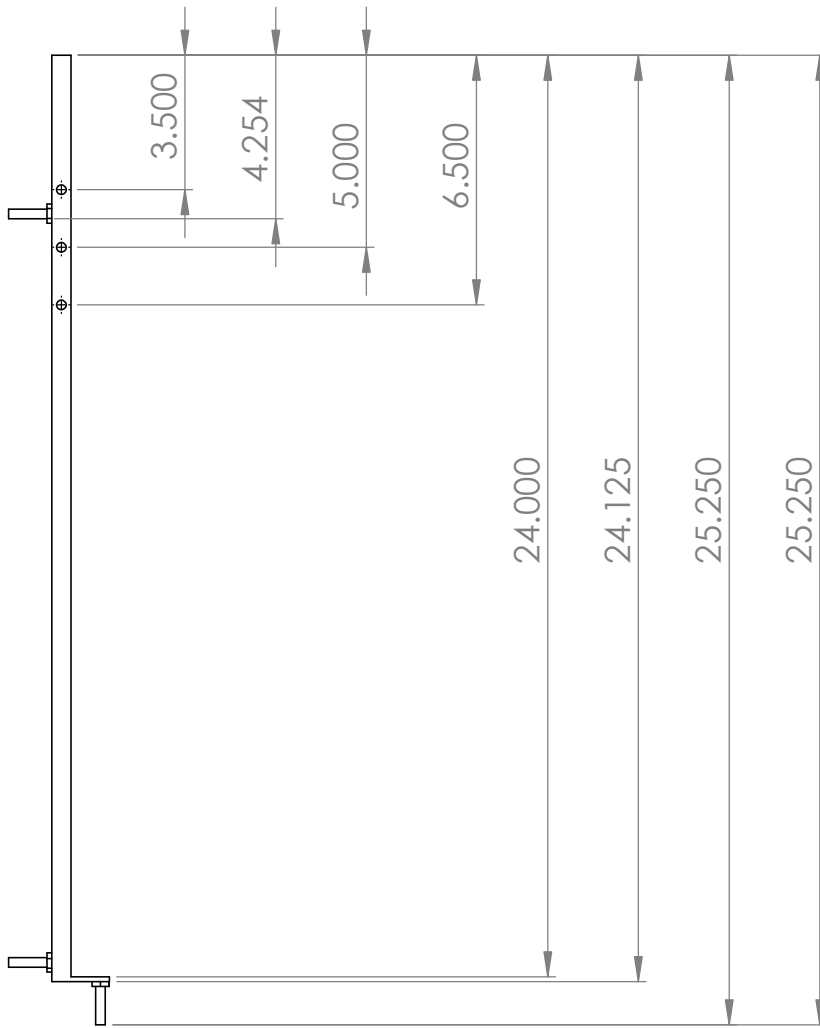

PROPRIETARY AND CONFIDENTIAL
 THE INFORMATION CONTAINED IN THIS DRAWING IS THE SOLE PROPERTY OF AAAMP. ANY REPRODUCTION IN PART OR AS A WHOLE WITHOUT THE WRITTEN PERMISSION OF AAAMP IS PROHIBITED.

		DIMENSIONS ARE IN INCHES All holes have a 0.25" diameter		NAME	DATE
				DRAWN	AH-S 1/30/2022
				CHECKED	PS 1/30/2022
				ENG APPR.	
				MFG APPR.	
				Q.A.	
				COMMENTS: Uses 1"x1/4" bolts welded on	
NEXT ASSY	USED ON	MATERIAL	Steel		
		FINISH	N/A		
APPLICATION		DO NOT SCALE DRAWING			

Left Rear Solar Mount

SIZE	DWG. NO.	REV.
A	06	
SCALE:1:10	WEIGHT:	SHEET 1 OF 1

2

1

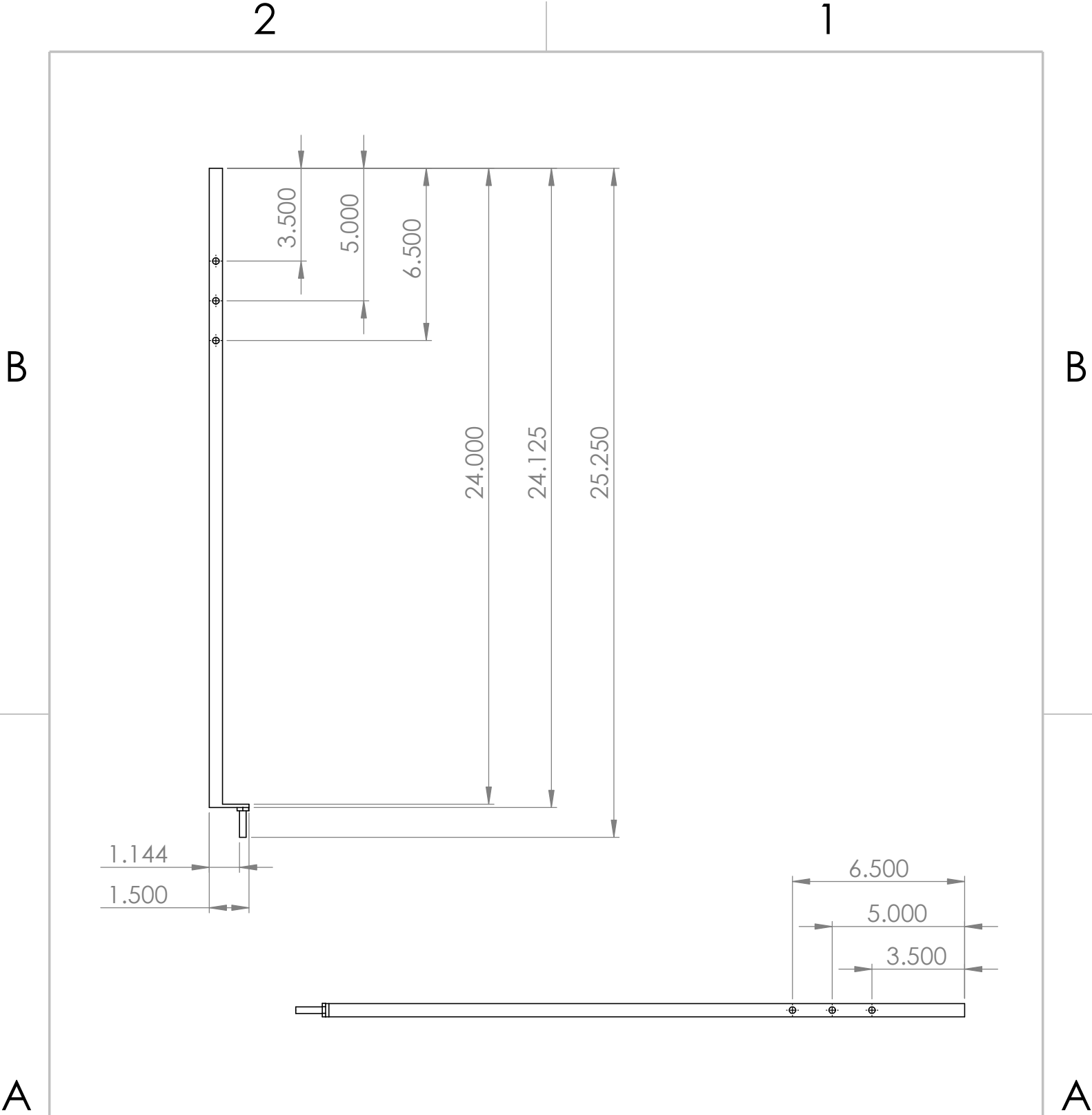

PROPRIETARY AND CONFIDENTIAL
 THE INFORMATION CONTAINED IN THIS DRAWING IS THE SOLE PROPERTY OF AAAMP. ANY REPRODUCTION IN PART OR AS A WHOLE WITHOUT THE WRITTEN PERMISSION OF AAAMP IS PROHIBITED.

		DIMENSIONS ARE IN INCHES All holes are 0.25" in diameter		NAME	DATE
				DRAWN	AH-S 1/30/2022
				CHECKED	PS 1/30/2022
				ENG APPR.	
				MFG APPR.	
				Q.A.	
				COMMENTS: Uses a 1"x1/4" bolt welded on	
NEXT ASSY	USED ON	MATERIAL	Steel		
		FINISH	N/A		
APPLICATION		DO NOT SCALE DRAWING			

Right Front Solar Mount

SIZE	DWG. NO.	REV.
A	07	
SCALE: 1:10	WEIGHT:	SHEET 1 OF 1

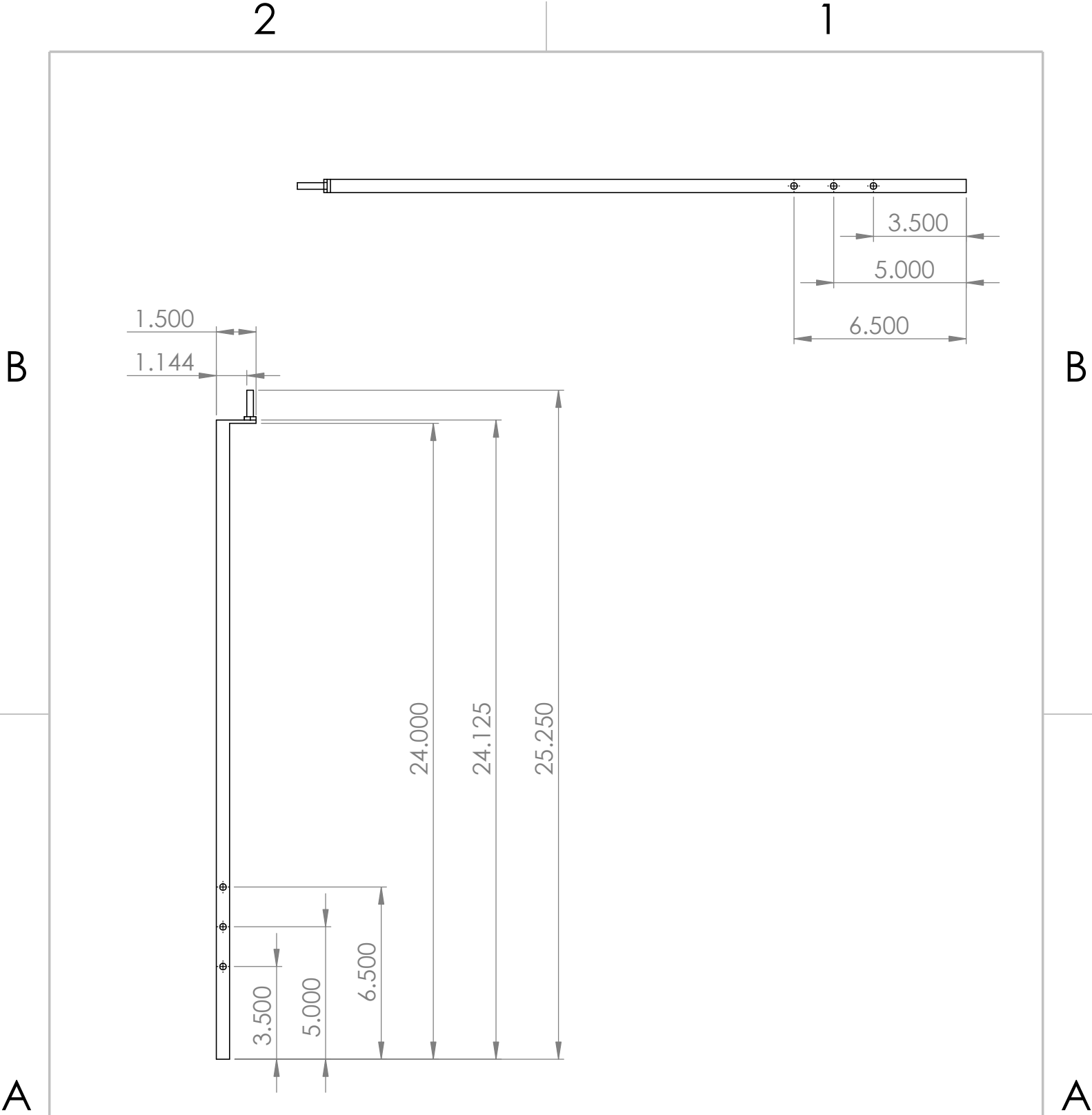

PROPRIETARY AND CONFIDENTIAL
 THE INFORMATION CONTAINED IN THIS DRAWING IS THE SOLE PROPERTY OF AAAMP. ANY REPRODUCTION IN PART OR AS A WHOLE WITHOUT THE WRITTEN PERMISSION OF AAAMP IS PROHIBITED.

		DIMENSIONS ARE IN INCHES Hole dia. .25 unless otherwise noted		NAME	DATE
			DRAWN	AH-S	1/30/2022
			CHECKED	PS	1/30/2022
			ENG APPR.		
			MFG APPR.		
			Q.A.		
			COMMENTS:	Uses a 1"x1/4" bolts welded on	
NEXT ASSY	USED ON	MATERIAL Steel			
		FINISH N/A			
APPLICATION		DO NOT SCALE DRAWING			

Right Rear Solar Mount		
SIZE A	DWG. NO. 08	REV.
SCALE:1:10	WEIGHT:	SHEET 1 OF 1

2

1

B

B

A

A

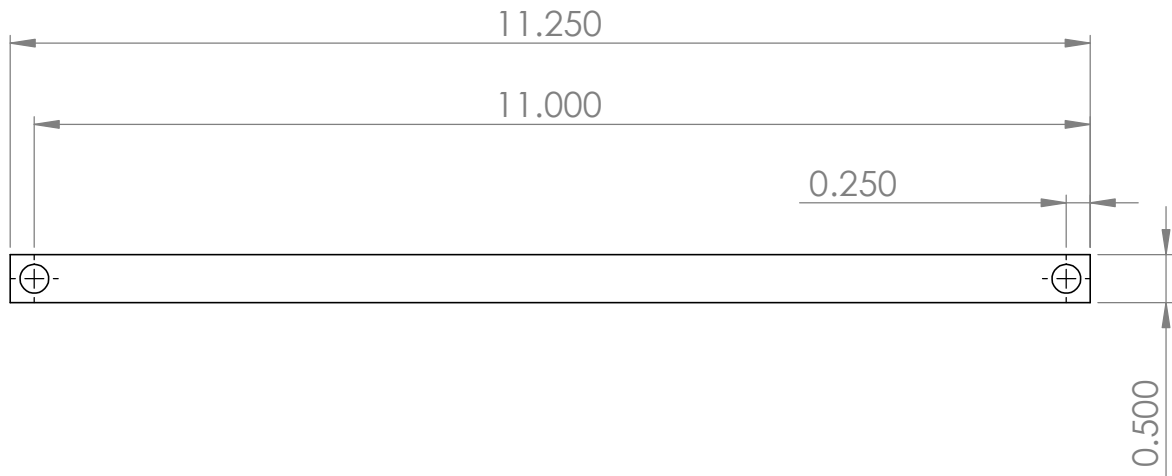

PROPRIETARY AND CONFIDENTIAL
 THE INFORMATION CONTAINED IN THIS DRAWING IS THE SOLE PROPERTY OF AAAMP. ANY REPRODUCTION IN PART OR AS A WHOLE WITHOUT THE WRITTEN PERMISSION OF AAAMP IS PROHIBITED.

		DIMENSIONS ARE IN INCHES Hole dia .3 unless otherwise noted 1/2" by 1/2" square tubing	NAME	DATE	<h1>A-Arm</h1>	
			DRAWN	AH-S 1/30/2022		
			CHECKED	PS 1/30/2022		
			ENG APPR.			
		MATERIAL	COMMENTS:		SIZE A DWG. NO. 09 REV. SCALE:1:5 WEIGHT: SHEET 1 OF 1	
		Steel				
Quantity	4	FINISH	N/A			
APPLICATION		DO NOT SCALE DRAWING				

1

2

1

B

B

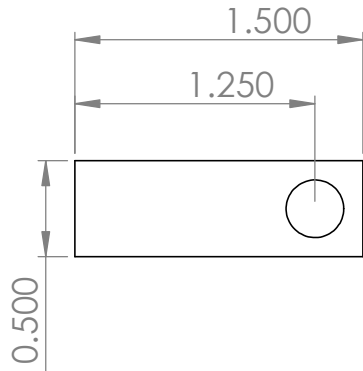
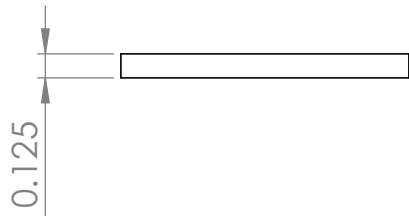

A

A

PROPRIETARY AND CONFIDENTIAL

THE INFORMATION CONTAINED IN THIS DRAWING IS THE SOLE PROPERTY OF AAAMP. ANY REPRODUCTION IN PART OR AS A WHOLE WITHOUT THE WRITTEN PERMISSION OF AAAMP IS PROHIBITED.

		DIMENSIONS ARE IN INCHES Hole dia .3 unless otherwise noted Holes are through all		NAME	DATE
			DRAWN	AH-S	1/30/2022
			CHECKED	PS	1/30/2022
			ENG APPR.		
			MFG APPR.		
			Q.A.		
			COMMENTS:		
Quantity	4	MATERIAL Steel			
		FINISH N/A			
APPLICATION		DO NOT SCALE DRAWING			

A-Arm Mount

SIZE	DWG. NO.	REV.
A	10	
SCALE:1:1	WEIGHT:	SHEET 1 OF 1

1

2

1

B

B

A

A

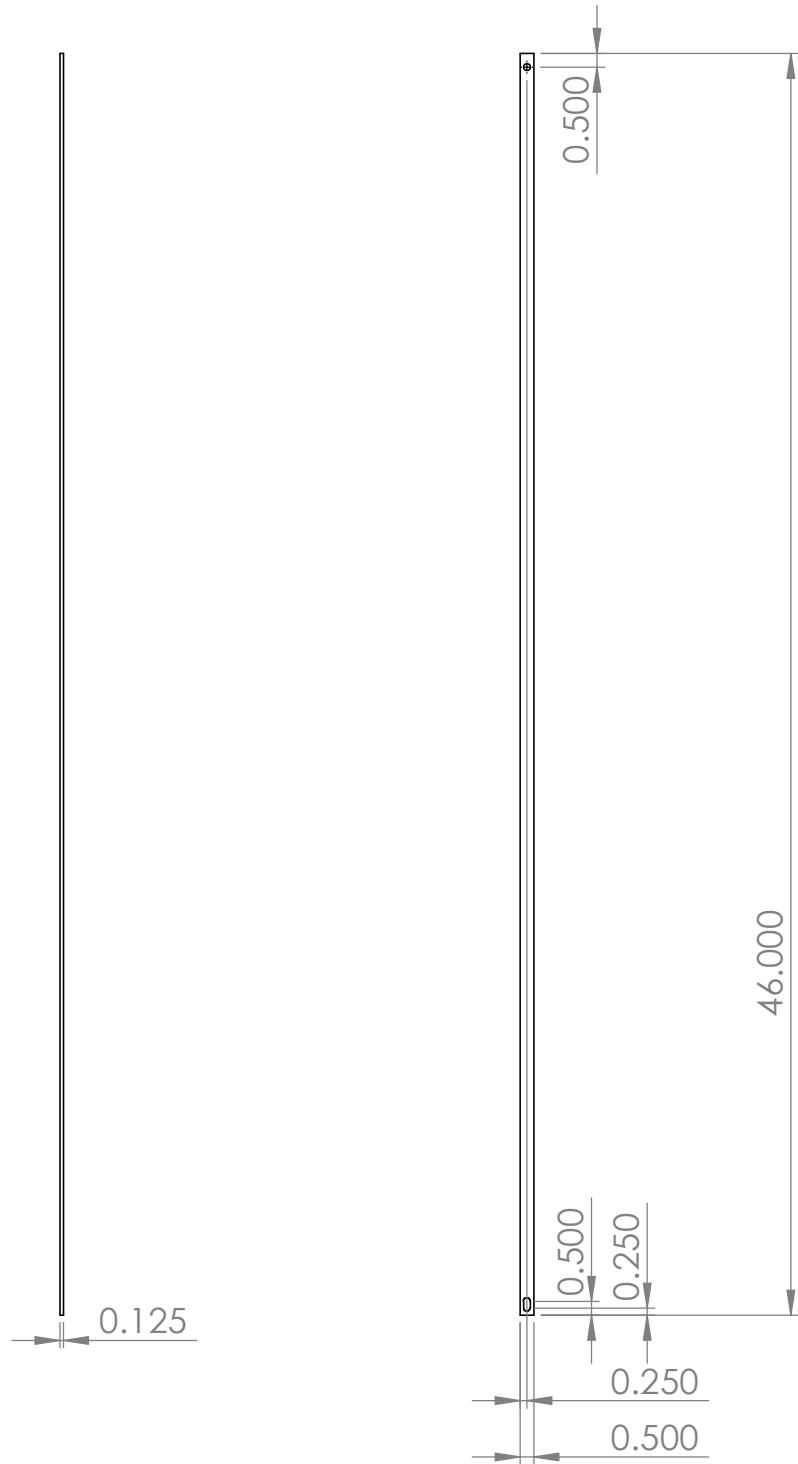

PROPRIETARY AND CONFIDENTIAL
 THE INFORMATION CONTAINED IN THIS DRAWING IS THE SOLE PROPERTY OF AAAMP. ANY REPRODUCTION IN PART OR AS A WHOLE WITHOUT THE WRITTEN PERMISSION OF AAAMP IS PROHIBITED.

		DIMENSIONS ARE IN INCHES TOLERANCES: THREE PLACE DECIMAL ±0.001 Hole Dia .3	NAME	DATE
			DRAWN	AH-S 4/5/2022
			CHECKED	PS 4/5/2022
			ENG APPR.	
			MFG APPR.	
			Q.A.	
			COMMENTS:	
Quantity	2	MATERIAL Steel		
		FINISH N/A		
APPLICATION		DO NOT SCALE DRAWING		

<h1>Solar Mount Cross Beam</h1>		
SIZE	DWG. NO.	REV.
A	13	
SCALE:1:10	WEIGHT:	SHEET 1 OF 1

1

2

1

B

B

A

A

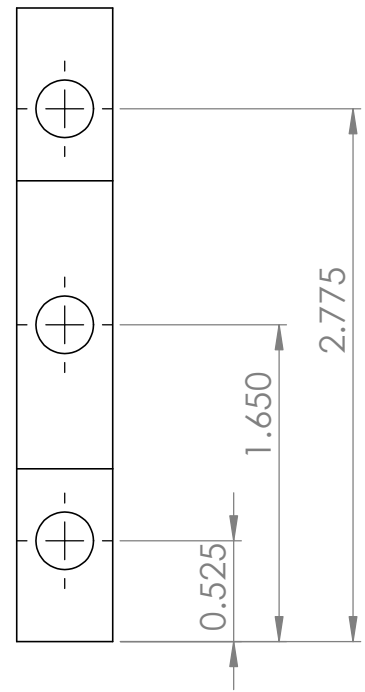
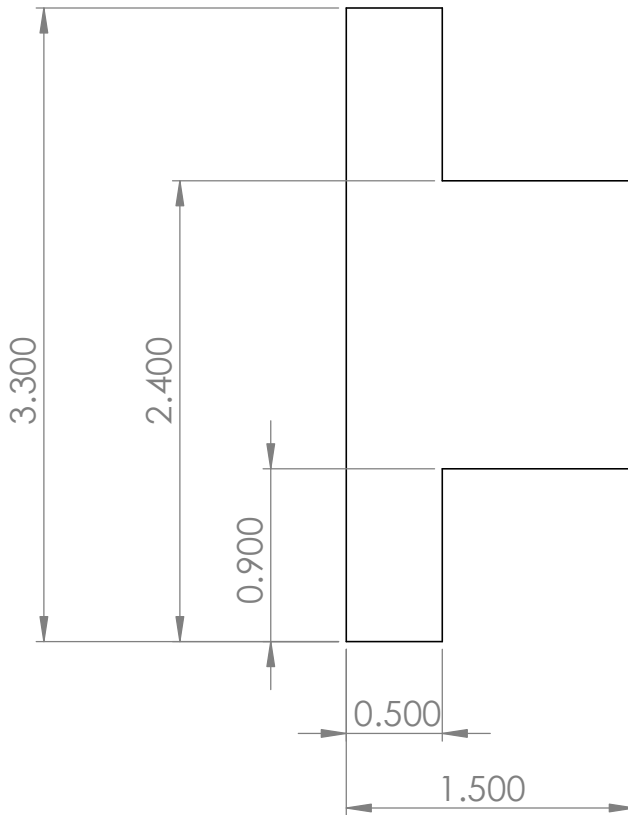

PROPRIETARY AND CONFIDENTIAL
 THE INFORMATION CONTAINED IN THIS DRAWING IS THE SOLE PROPERTY OF AAAMP. ANY REPRODUCTION IN PART OR AS A WHOLE WITHOUT THE WRITTEN PERMISSION OF AAAMP IS PROHIBITED.

		DIMENSIONS ARE IN INCHES TOLERANCES: ± 0.001 Hole dia .3		NAME	DATE
				DRAWN	AH-S 4/7/22
				CHECKED	PM 4/7/22
				ENG APPR.	
				MFG APPR.	
				Q.A.	
				COMMENTS:	
NEXT ASSY	USED ON	MATERIAL	FINISH		
		Steel	N/A		
APPLICATION		DO NOT SCALE DRAWING			

solid vibration isolator BP-14

SIZE	DWG. NO.	REV.
A	14	
SCALE:1:1	WEIGHT:	SHEET 1 OF 1

2

1